

0000000000

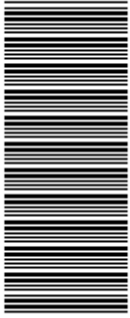

higher education & training

Department:
Higher Education and Training
REPUBLIC OF SOUTH AFRICA

T370(E)(J22)T
AUGUST EXAMINATION

NATIONAL CERTIFICATE

DIESEL TRADE THEORY N2

(11040192)

22 July 2014 (Y-Paper)
13:00–16:00

This question paper consists of 5 pages.

DEPARTMENT OF HIGHER EDUCATION AND TRAINING
REPUBLIC OF SOUTH AFRICA
NATIONAL CERTIFICATE
DIESEL TRADE THEORY N2
TIME: 3 HOURS
MARKS: 100

INSTRUCTIONS AND INFORMATION

1. Answer ALL the questions.
 2. Read ALL the questions carefully.
 3. Number the answers according to the numbering system used in this question paper.
 4. Write neatly and legibly.
-

QUESTION 1

- 1.1 There are two main types of Compression Ignition (CI) engines, namely Direct Injection models and Indirect Injection models.
- 1.1.1 State THREE advantages of Direct Injection engines compared to Indirect Injection engines. (3)
- 1.1.2 State THREE disadvantages of Direct Injection engines compared to Indirect Injection engines. (3)
- 1.2 Draw a neat labelled sketch of a fuel-supply system that is used on four-cylinder diesel engines.
- Include the following components in the sketch:
Fuel tank, Fuel supply pipe, Water trap filter, Low pressure fuel lift pump, Secondary filter, Primary filter, High pressure fuel lines and Injectors. (8)
- 1.3 Name FOUR types of fuel filter materials used in diesel fuel systems. (4)
- 1.4 State TWO functions of the copper washer that is fitted between the injector and the cylinder head. (2)
- [20]**

QUESTION 2

FIGURE 1 shows a synchronising unit.
Refer to the figure and answer the questions:

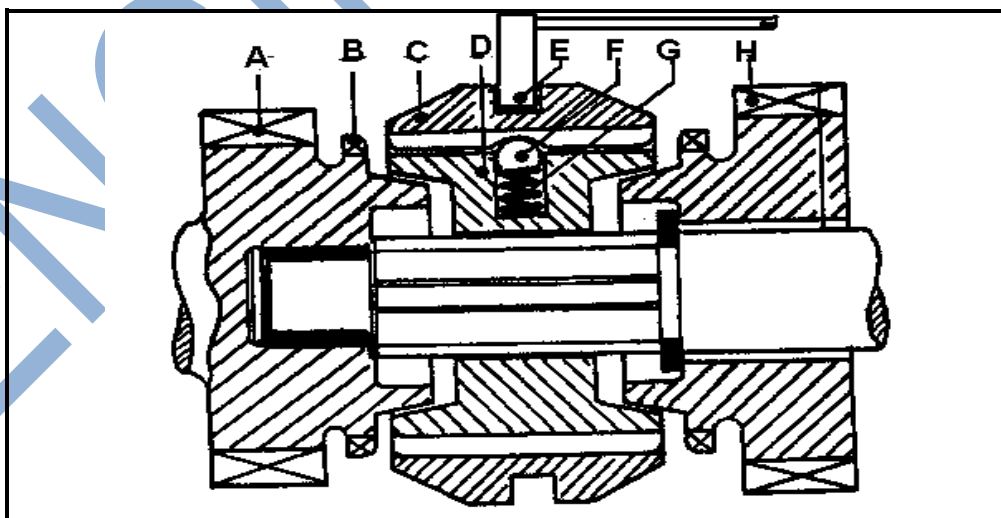
**FIGURE 1**

- 2.1 Name this synchronising unit. (1)
- 2.2 List the labelled parts (A–H) in your ANSWER BOOK. (8)

- 2.3 Explain the operation of this synchronising unit during gear changing. (5)
- 2.4 State FOUR functions of a gearbox. (4)
- 2.5 State ONE function of the following:
- 2.5.1 Interlocking mechanism (1)
- 2.5.2 Locking mechanism (1)
- [20]**

QUESTION 3

- 3.1 State FOUR safety requirements of a steering mechanism. (4)
- 3.2 Give TWO reasons why the correct castor angle is a necessity. (2)
- 3.3 Show, by means of TWO labelled sketches, the difference between a *positive castor* and a *zero castor*. (8)
- 3.4 Name FOUR types of steering boxes used on light vehicles. (4)
- 3.5 Name the TWO types of wheel balancing methods. (2)
- [20]**

QUESTION 4

FIGURE 2 below shows a final drive and differential assembly.
Refer to the figure and answer the questions:

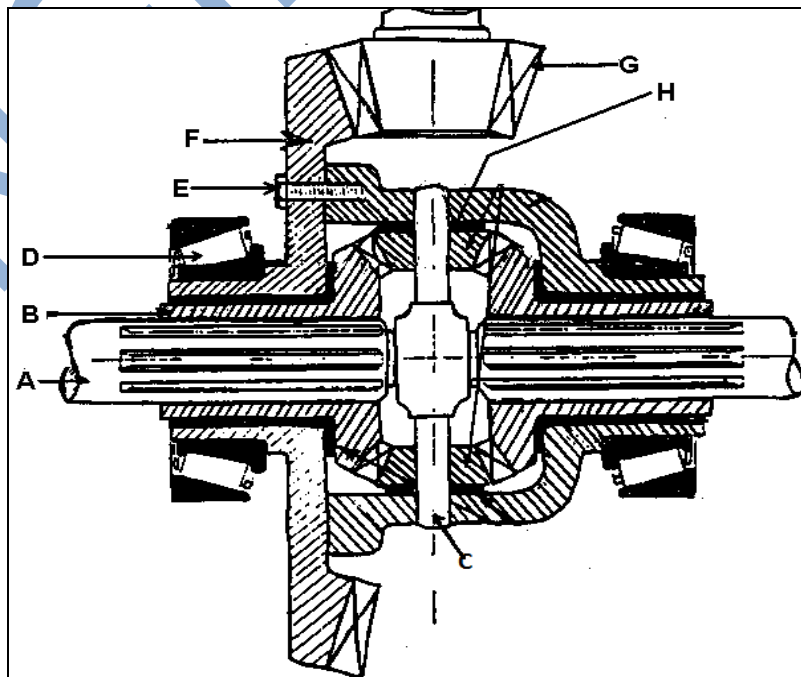

FIGURE 2

- 4.1 List the labelled parts (A–H) in your ANSWER BOOK. (8)
- 4.2 Explain the power flow through this assembly when the vehicle is moving forward. (4)
- 4.3 State TWO advantages and two disadvantages of:
- 4.3.1 Semi floating rear axles (4)
- 4.3.2 Fully floating rear axles (4)
- [20]**

QUESTION 5

- 5.1 Bleeding of a braking system can be described as the removal of air from the system.
- Explain the procedure to be followed when bleeding the brakes in a hydraulic brake system. (6)
- 5.2 As a diesel mechanic it is important to identify problems in a braking system.
- Give THREE reasons for each of the following common brake problems that may occur on a vehicle:
- 5.2.1 Excessive brake pedal free play (3)
- 5.2.2 Spongy brake pedal (3)
- 5.2.3 Dragging brakes (3)
- 5.3 Name TWO types of brake callipers. (2)
- 5.4 State THREE properties of a good hydraulic brake fluid. (3)
- [20]**

TOTAL: 100